

# Low-Cost Magnetic Levitation Project Kits

Using inexpensive experiments to teach analysis and design in undergraduate feedback courses

A new magnetic levitation project option has been developed for the final laboratory assignment in a junior- and senior-level control systems course (6.302 Feedback Systems) offered by the Department of Electrical Engineering and Computer Science at the Massachusetts Institute of Technology [1]. The project was made available to students in the fall of 2003. The system is similar to classroom demonstration systems first described in [2] and [3], which suspend an object below an electromagnet. In our project, students assemble and modify individual kits to create their own desktop-sized systems with analog control. The unmodified basic system presented to the students is marginally stable, and students must analyze and redesign the system to improve its performance. The main goal of the project is to provide a challenging design problem that captures student interest and allows for open-ended solutions.

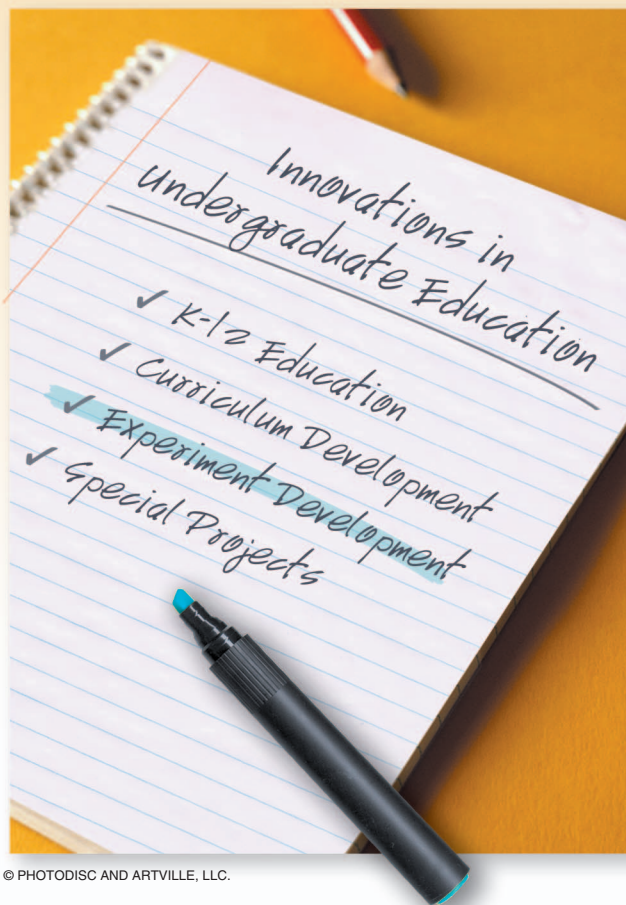

© PHOTODISC AND ARTVILLE, LLC.

By Kent H. Lundberg,  
Katie A. Lilienkamp,  
and Guy Marsden

**The Basic System**  
Figures 1 and 2 show assembled magnetic levitation systems. The kit is easy to assemble, but initial performance of the device is intentionally poor. When assembled as described, the system exhibits high sensitivity to initial conditions and considerable visible wobble of the object. This kit is based on a low-cost design developed in [4], which uses proportional control and is marginally stable. The parts kit includes all of the parts listed in Figure 3, while the students are required to provide the support stand and the object for levitation.

The schematic of the basic system is shown in Figure 4. A prewound solenoid around a soft-steel bolt serves as the electromagnet. A Hall-effect sensor mounted at the base of the solenoid senses the proximity of a permanent magnet attached to the levitated object. The output voltage of the sensor drives the input of a fan-management chip, which produces a pulse-width modulated (PWM)

drive signal to a motor drive chip. This PWM signal adjusts the average current in the solenoid, which controls the magnetic field.

## We intentionally present students with a device that is poorly instrumented and poorly compensated, and we expect the students to analyze sensor performance and perform compensator design.

Damping is provided by washers attached to the levitated object. Losses and eddy currents in the ferrous material help to dampen the vertical wobble of the object [4]. The system is sensitive to initial conditions and requires a steady hand. Of course, the measurement of the magnetic field from the levitated object is corrupted by the field from the electromagnet, so the position measurement is

far from ideal. For the basic system, however, the Hall-effect sensor is an inexpensive and adequate solution.

### Lab Project

After the basic system is demonstrated in a classroom lecture, each student receives an individual kit along with assembly instructions for building the magnetic levitation device. The laboratory assignment challenges the students to modify the system to improve basic system stability, transient performance, and disturbance rejection.

We intentionally present students with a device that is poorly instrumented and poorly compensated, and we expect the students to analyze sensor performance and perform compensator design. The project is open-ended, however, and students are encouraged to explore other areas of improvement. Modifications can include sensor selection and placement; the design of the solenoid actuator; the magnetic, geometric, and inertial characteristics of the

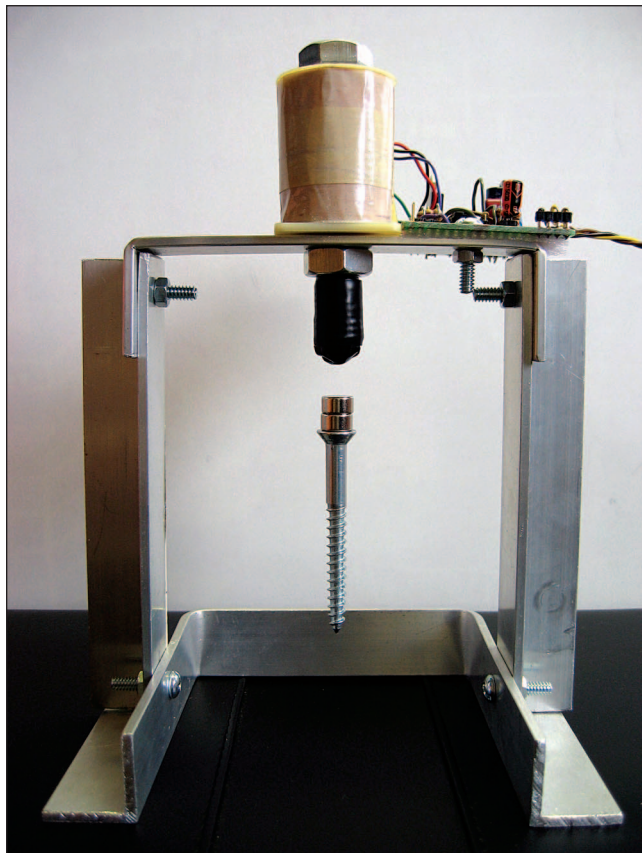

**Figure 1.** Student-built system with an aluminum stand. The system levitates a large metal screw. This industrial-looking system won the award for lowest power consumption.

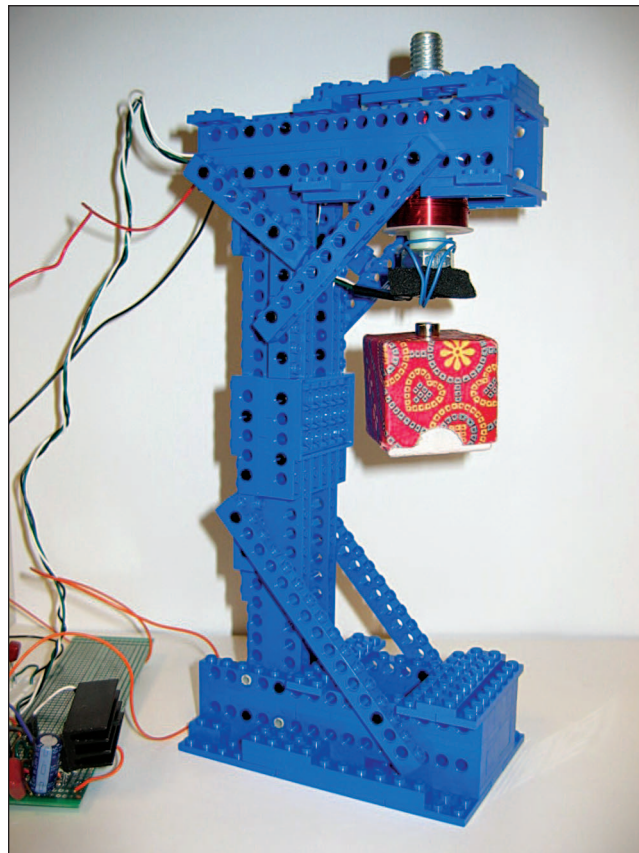

**Figure 2.** Student-built system with a LEGO stand. The system levitates an attractive paper box. This creative support system placed in the Most Artistic category.

levitated object; the power electronics; and the analog controller. Digital controllers are not used in the project.

The lab assignment requires that at a minimum the students design an analog compensator to improve the stability and disturbance rejection of the basic system. Students need to modify the system to take step-response measurements by adding an electrical drive input. Once the desired loop transfer function is determined, the circuit must be modified to include the analog compensator circuitry. Most students find this requirement easy to satisfy with a simple op-amp circuit implementing a lead compensator.

### Cost of Kit Components

Magnetic levitation projects have long been used in control systems laboratories [5], [6]; textbooks [7], [8]; and hobbyist construction articles [9], [10]. These projects require custom winding of the solenoid, and they dissipate considerable power. In this effort, the kit we provide to each student is theirs to keep, and we anticipate that several dozen students will elect to complete this project each year. Minimizing the cost of the kits is therefore a key issue.

The total cost of the laboratory kits given to the students is less than US\$20. Several factors keep the cost low. In particular, the system is designed with commodity integrated-circuit power electronics and an inexpensive prewound solenoid. Also, a prebuilt stand is not provided to the students. The cost of the parts included in the kits is listed in Figure 3.

### End-of-Term Contest

Beyond the basic modifications required by the laboratory assignment, we motivate additional improvements through an end-of-term contest. Students are challenged to improve specific performance measures and compete against other students. There are five categories of competition.

- 1) *Widest dynamic range* is defined as the largest periodic movement of the levitated object, measured with a ruler, for a square-wave or sine-wave input.
- 2) *Best disturbance rejection* is defined as the largest ratio between heaviest object levitated to lightest object levitated, using the same system settings and number of magnets, with no tweaking allowed.
- 3) *Heaviest object lifted* is measured by weighing the levitated object on a scale, with a design maximum of one magnet.
- 4) *Lowest power consumption* is measured with an ammeter on the single 15 V supply.
- 5) *Most artistic system* as judged by the teaching staff, acknowledging that beauty is in the eye of the beholder.

Winning students in the first four categories are awarded significant extra credit for the lab, while the prize for the final category is a gift certificate for a local ice cream shop. Two of the winning systems are shown in Figures 1 and 2.

## Beyond the basic modifications required by the laboratory assignment, we motivate additional improvements through an end-of-term contest.

### Student Experiences

MIT 6.302 Feedback Systems covers of a wide variety of electronic applications and physical systems. For the final laboratory experiment in the course, students are given a choice of four laboratory assignments; namely, compensation of a thermal system, construction of a ball-balancing system, experimental work with phase-lock loops, or the magnetic levitator system. In its first offering, over 40% of the class chose to construct the magnetic levitator.

Overall, student reactions were positive. Below are some of the responses students gave when surveyed about the class.

U1	LM7805	Voltage Regulator	\$ 0.48
U2	MIC502	Fan-Management IC	\$ 1.91
U3	LMD18201	Motor H-Bridge IC	\$ 8.13
U4	SS495A	Hall-Effect Sensor	\$ 2.02
C1	470 $\mu$ F	Electrolytic Capacitor	\$ 0.42
C2	1 $\mu$ F	Ceramic Capacitor	\$ 0.34
C3	0.1 $\mu$ F	Ceramic Capacitor	\$ 0.09
C4	0.01 $\mu$ F	Ceramic Capacitor	\$ 0.11
		Prewound Solenoid	\$ 3.50
		Soft-Steel Carriage Bolt	\$ 0.40
		Neodymium Magnets (2)	\$ 0.45
		Heat Sink for LMD18201	\$ 0.93
			Total \$ 18.78

**Figure 3.** Kit contents with costs for quantities of 100. The labels refer to the schematic in Figure 4. The kit contains everything the students need except for a support stand and an object for levitation. Maintaining the cost under US\$20 enables the students to keep their systems at the conclusion of the class.

- “It’s fun and you can take it home. Unlike other EE labs, you can actually see what your circuit is doing with your eyes; you don’t have to take the scope’s word for it.”
- “It was a cool problem and satisfying to complete.”
- “[The best part was] the ‘cool’ factor.”
- “I got to keep it.”

## Many student have their systems on display in their dormitory rooms, and some have even featured their completed system on their personal Web sites.

Followup discussions reveal many student have their systems on display in their dormitory rooms, and some have even featured their completed system on their personal Web sites.

### Publicity

Several MIT courses allow students to build and keep small mechanical systems. These classes include 2.670 Mechanical Engineering Tools, in which students build a functional Stirling engine, and 8.02 Physics II, in which students com-

pete to build small electric motors. Given the choice between another math class and a class that builds something “cool,” many students will opt for the latter. These student-completed projects become conversation pieces in the student dormitories and living groups that can attract future students.

A secondary goal of this project is to publicize courses in control systems. In this regard, we succeeded beyond our wildest dreams when the picture in Figure 5 was published on the front page of the student newspaper [11].

### Conclusions

These low-cost magnetic suspension kits provide students with an open-ended design problem. The performance of the basic system is designed

to be inadequate, allowing students to apply their knowledge to implement improvements in sensors, magnetics, power electronics, and compensation electronics.

In the first offering of this lab project, student reaction was positive. The low cost of the kits allows each student to personalize their kit and keep the finished product at the end of the term. This laboratory assignment was successful in providing an open-ended design challenge, providing the students with real hardware experience and providing publicity for the class.

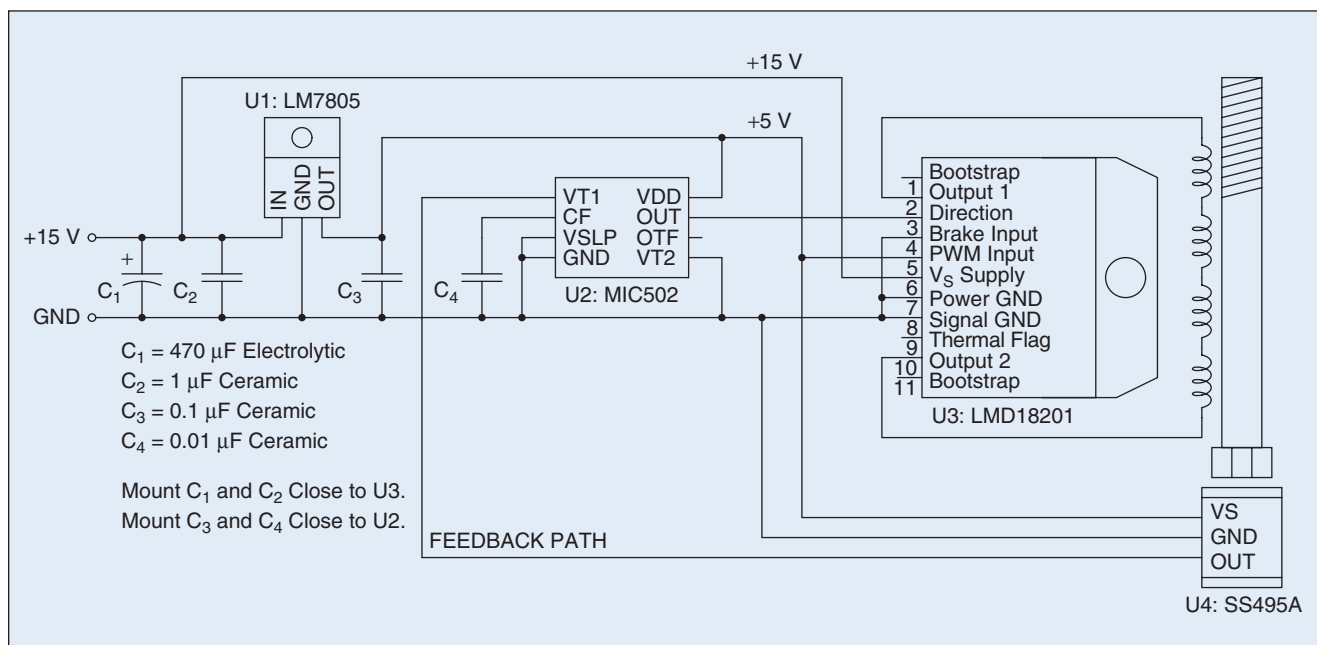

**Figure 4.** Schematic of the magnetic levitation system. The position of the levitated object is sensed by the SS495 Hall-effect sensor, which is mounted below the electromagnet. The output voltage of the sensor drives the input of the MIC502 fan-management chip. The fan-management chip produces a PWM signal for the LMD18201 motor drive H-bridge chip. This PWM drive adjusts the average current in the solenoid, which controls the magnetic field.

## Acknowledgments

We wish to thank the prize-winning students Adam Kumpf (Figure 1) and Alex Crumlin (Figure 2). The photograph in Figure 5 is courtesy of Brian Hemond and The Tech. K.A. Lilienkamp would like it known that K.H. Lundberg insisted on the inclusion of Figure 5. Special thanks to National Semiconductor for a generous donation of LMD18201 chips.

## References

- [1] K.A. Lilienkamp and K.H. Lundberg, "Low-cost magnetic levitation project kits for teaching feedback system design," in *Proc. 2004 Amer. Control Conf.*, Boston, MA, June 2004, pp. 1308–1313.
- [2] H.H. Woodson and J.R. Melcher, *Electromechanical Dynamics Part I*. New York: Wiley, 1968, pp. 193–200.
- [3] J.K. Roberge, *Operational Amplifiers: Theory and Practice*. New York: Wiley, 1975, pp. 214–217.
- [4] G. Marsden. (2003, Sept.). Levitation! *Nuts and Volts Mag.* [Online]. 24(9), pp. 58–61. Available: <http://www.arttec.net/Press/N&V/Levitation.html>
- [5] S.A. Green, R.S. Hirsch, and K.C. Craig, "Magnetic levitation device as teaching aid for mechatronics at Rensselaer," *Proc. ASME Dynamic Syst. and Control Division*, vol. 57, no. 2, pp. 1047–1052, 1995.
- [6] K. Craig, T. Kurfess, and M. Nagurka, "Magnetic levitation testbed for controls education," *Proc. ASME Dynamic Syst. and Control Division*, vol. 64, pp. 83–88, 1998.
- [7] G.F. Franklin and J.D. Powell, *Digital Control of Dynamic Systems*. Reading, MA: Addison-Wesley, 1980.
- [8] B. Shahian and M. Hassul, *Control System Design Using MATLAB*. Englewood Cliffs, NJ: Prentice-Hall, 1993, pp. 455–465.
- [9] D. Williams, "Electromagnetic levitator," *Electronics Now*, vol. 67, no. 2, pp. 33–34, 67–70, Feb. 1996.
- [10] J. Cicon, "Building a magnetic ball levitator," *Popular Electronics*, vol. 13, no. 5, pp. 48–52, 78, May 1996.
- [11] *The Tech*, vol. 123, no. 61, p. 1, Dec. 5, 2003.

**Kent H. Lundberg** ([klund@mit.edu](mailto:klund@mit.edu)) attended the Massachusetts Institute of Technology, earning a Ph.D. in Electrical Engineering in 2002. He is currently a lecturer with the Department of Electrical Engineering and Computer Science at MIT. His research interests include the application of control theory to problems in analog circuit design. He is the Associate Editor for History of this Magazine. He consults for several industry corporations and organizations, and he collects old textbooks on radar, nuclear energy, and control. He can be contacted at MIT EECS 38-483, 77 Massachusetts Avenue, Cambridge, MA 02139

**Katie A. Lilienkamp** holds B.S. and M.S. degrees in Mechanical Engineering from MIT and is currently pur-

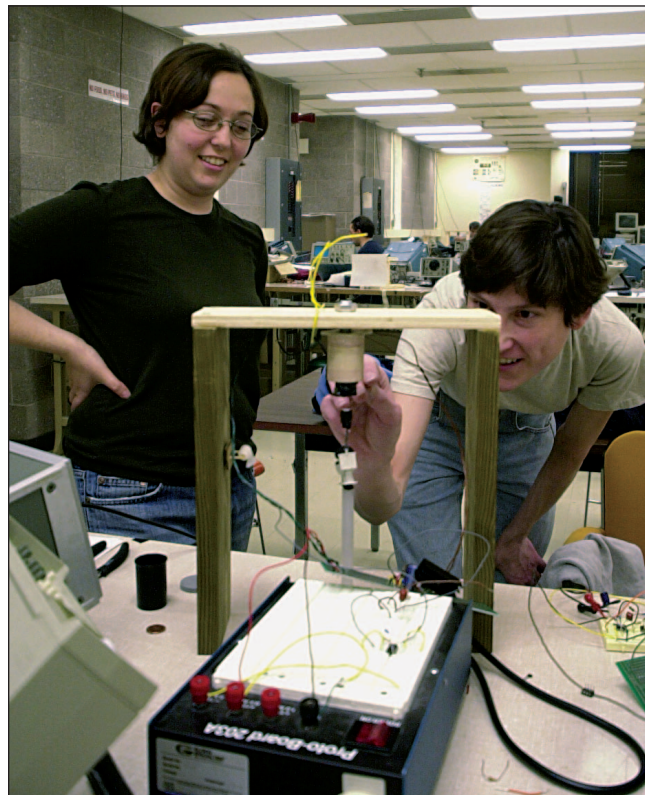

**Figure 5.** This photograph ran on the front page of the MIT student newspaper with the caption, "Students crowd the electronics lab in 38–500 the night before projects are due for many classes. Rikky Muller (left) demonstrates her 6.302 final lab project, a magnetically levitated miniature toilet complete with real toilet paper, to Katherine Lilienkamp." The authors did not expect (but were very pleased) to receive this much publicity for the projects! Reprinted courtesy of Brian Hemond and The Tech.

suing a Ph.D. in system dynamics and control. Her doctoral research focuses on the design of electromagnetic actuators. She has been involved in the creation of ActivLab labware for teaching the sophomore-level Mechanical Engineering course 2.003 Modeling Dynamics and Control.

**Guy Marsden** is a self-taught electrical engineer with a fine arts background. He operates ART TEC ([www.arttec.net](http://www.arttec.net)), which specializes in consulting with artists and inventors to realize their ideas and patent prototypes. He makes wood furniture in his solar-heated workshop in Maine, and he exhibits artwork in several media throughout the United States.

