

## Grounding Washer Installation Procedure for Enphase Microinverters

---

### Purpose

As an alternative to installing a continuous grounding electrode conductor connected to each microinverter chassis, a grounding washer may be used to ground the microinverter to grounded racking. CSA recently completed the evaluation and approval of the Wiley Electronics "WEEB" grounding washers for use with the Enphase Microinverter. This document provides the installation procedure and torque specifications. The Enphase compatible racking models that have listed grounding washers available are included on the last page of this App Note.

### Installation Procedure

- Install a minimum of one grounding washer per microinverter.
- Each microinverter requires a stainless steel fender washer on the topside of the Enphase Microinverter mounting bracket for the bolt that passes through the grounding washer.
- Torque the microinverter fasteners. The values listed below are minimum torque requirements. Wiley Electronics and the racking manufacturers will have specific torque specifications in their installation documents. We recommend using the highest of the recommended values.

1/4" mounting hardware – 45 in-lbs minimum

5/16" mounting hardware – 80 in-lbs minimum

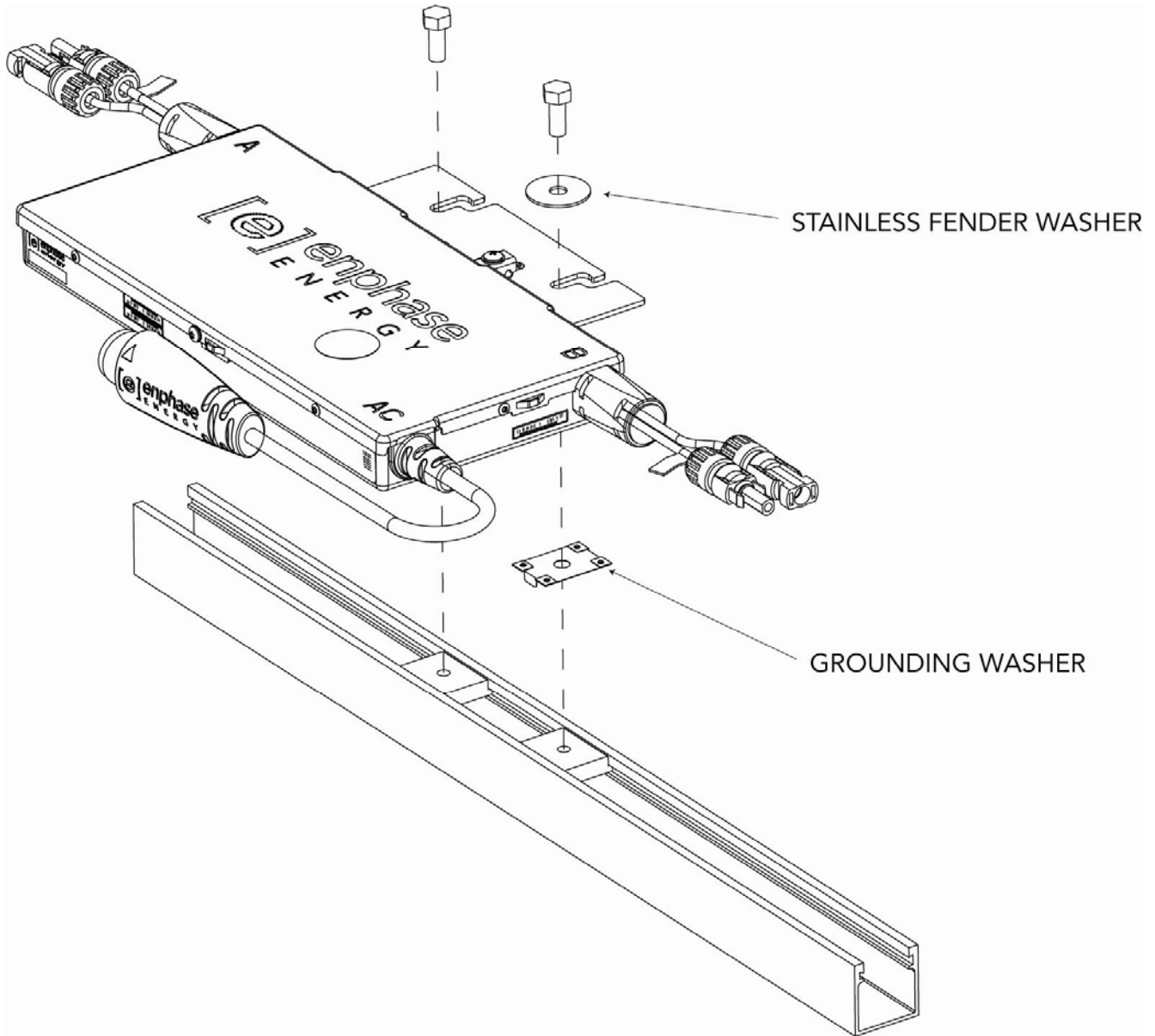

The Enphase Microinverter model D380 is shown. The installation procedure and grounding washer model numbers also apply to the Enphase Microinverter models M190 and M210.

## Compatible Racking/Washers

### AEE

Module Rail	Fastener Information	Grounding Washer
SnapNRack	Slide nut with 5/16 hex head bolt	WEEB-PMC

### Conergy

Module Rail	Fastener Information	Grounding Washer
Suntop	Quickstone slide nut with M8 socket head cap screw	WEEB-CMC

### Direct Power and Water

Module Rail	Fastener Information	Grounding Washer
Power Rail	¼" hex head bolt, washer, nut, for top rail mount	WEEB-DMC

### IronRidge

Module Rail	Fastener Information	Grounding Washer
Light Rail XRL	¼" hex head bolt, washer, nut, for top rail mount	WEEB-DMC

### Krannich Solar

Module Rail	Fastener Information	Grounding Washer
K2 Systems	Slide nut with M8 socket head cap screw	WEEB-KMC

### ProSolar

Module Rail	Fastener Information	Grounding Washer
Rooftrac	Slide nut with 5/16" hex head bolt	WEEB-PMC

### Unirac

Module Rail	Fastener Information	Grounding Washer
Solarmount Light	¼" hex head bolt, washer, nut, for top rail mount	WEEB-DMC
Solarmount Standard	¼" hex head bolt, washer, nut, for top rail mount	WEEB-DMC
Solarmount HD	¼" hex head bolt, washer, nut, for top rail mount	WEEB-DMC